

HV Fan Range

High Volume Belt Drive Fans

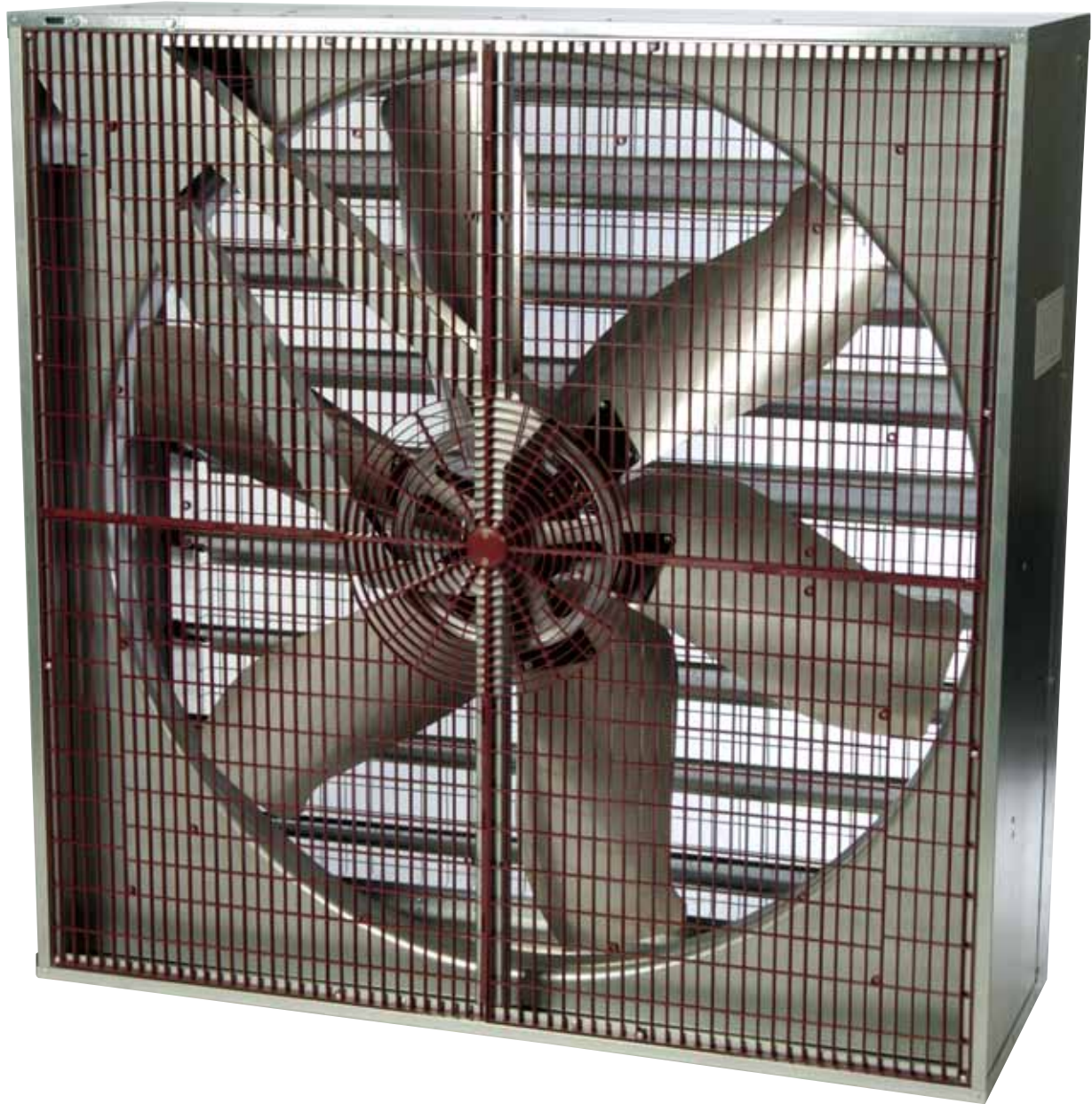

The Hydor Belt Drive fan unit is specifically designed to ventilate larger buildings, by moving substantial amounts of air at low pressure with minimal energy consumption.

Available in three sizes 800mm, 1000mm and 1250mm diameter, each with single or three phase motors and the option of louvers and guards.

Constructed from galvanised steel with a specially designed stainless steel propeller, these fans are extremely hard wearing

and robust in application. The drive mechanism comprises of a sealed for life maintenance free ball bearings, which means low noise and vibration levels.

The HV Range incorporates a centrifugal operated back draught shutter or an automatic louvre shutter.

Units are supplied fully assembled complete with standard safety guards.

HV Fan Range

High Volume Belt Drive Fans

Features



- A crossed steel framework with the fan hub positioned centrally. Fan blades and pulley are located on opposite sides, improving load balancing, thereby increasing bearing and fan life.
 - The belt is from reinforced rubber which is easily replaced locally. Belt tensioning can be undertaken without removing the guards by using two bolts on the fan casing.
 - Easy access to the motor for servicing and maintenance.
 - The propeller comprises six self-cleaning blades constructed from 304 stainless steel. The aerodynamic blade design ensures volume displacement at low blade pressure.
 - Fan housing is manufactured from galvanised sheet steel, corrosion resistant for durability and longevity.
 - Each fan is fitted with a wire mesh safety guard either side of the unit.
- The heavy duty construction of the louvres prevents the overlapping slats from vibrating at high air flow. When not in operation, heat loss is reduced by the louvres closing automatically. Air delivery normally lost due to dirty shutters or to hold shutters open is eliminated.
- The louvres are opened by a centrifugal mechanism; which means that once opened, the louvres do not sap the performance of the fan.
 - Component spares are usually available from stock.
 - 12 months product warranty.

Accessories



- Suspension chain hanging kit.
- Louvre-side guard.
- Nylon guards.
- A full range of both automatic and manual infinitely variable or stepped transformer type controls.

HV Fan Range

Technical Specification

Motors

The Motors are to be foot mounted totally enclosed metric type to IP55, with sealed for life bearings, and class F insulation, suitable for operating temperatures up to 50°C. Motors are constructed with a finned aluminium casing to provide excellent heat dissipation resulting in a flexible and durable motor.

Impellers

Propeller blades are fixed pitch and manufactured from 304 stainless steel. The six blades are attached to a mild steel powder coated hub. The complete assembled propeller unit is balanced to grade G6.3.

Mounting

Unit can be supplied with suspension kit for ceiling mounting. Comes as standard with pre-punched holes in casing side for wall / cable-end mounting.

Quality Management

All units are designed and manufactured with procedures as defined in BS EN ISO 9001:2000. All HV units are to be tested to ISO 5801: 1997 (airside performance) and BS848 Pt 2:1985 (sound performance).

Performance & Electrical Data

Product Code	Airflow m ³ /s @ Static Pressure Pa.					Speed (r/min)	Motor Electrical Data 220-240V/1Ph/50Hz			Sound Level dBA @ 3m	Weight (kg)	Weight inc Louvre (kg)
	0	25	50	75	100		Power Watts	FL Amps	Start Amps			
HV80	5.000	4.472	3.916	3.166	2.388	630	550	4.4	12.1	75	42	49
HV100	8.055	7.083	6.305	4.722	3.583	503	750	6.3	17.3	76	58	64
HV125 (1.1kW)	11.94	8.888	8.194	6.944	5.750	485	1100	7.5	26.3	78	80	90
HV125 (1.5kW)	13.33	10.27	9.450	8.890	7.30	540	1500	9.64	33.8	82	82	92

Product Code	Airflow m ³ /s @ Static Pressure Pa.					Speed (r/min)	Motor Electrical Data 400/3Ph/50Hz			Sound Level dBA @ 3m	Weight (kg)	Weight inc Louvre (Kg)
	0	25	50	75	100		Power Watts	FL Amps	Start Amps			
HV80	5.000	4.472	3.916	3.166	2.388	630	550	1.50	4.50	75	42	49
HV100	8.055	7.083	6.305	4.722	3.583	503	750	2.00	6.00	76	58	64
HV125 (1.1kW)	11.94	8.888	8.194	6.944	5.750	485	1100	2.80	8.40	78	80	90
HV125 (1.5kW)	13.33	10.27	9.450	8.890	7.30	540	1500	3.20	9.60	82	82	92

Note: Motor electrical data is approximate, as it varies from one motor manufacturer to another



Dimensional Data

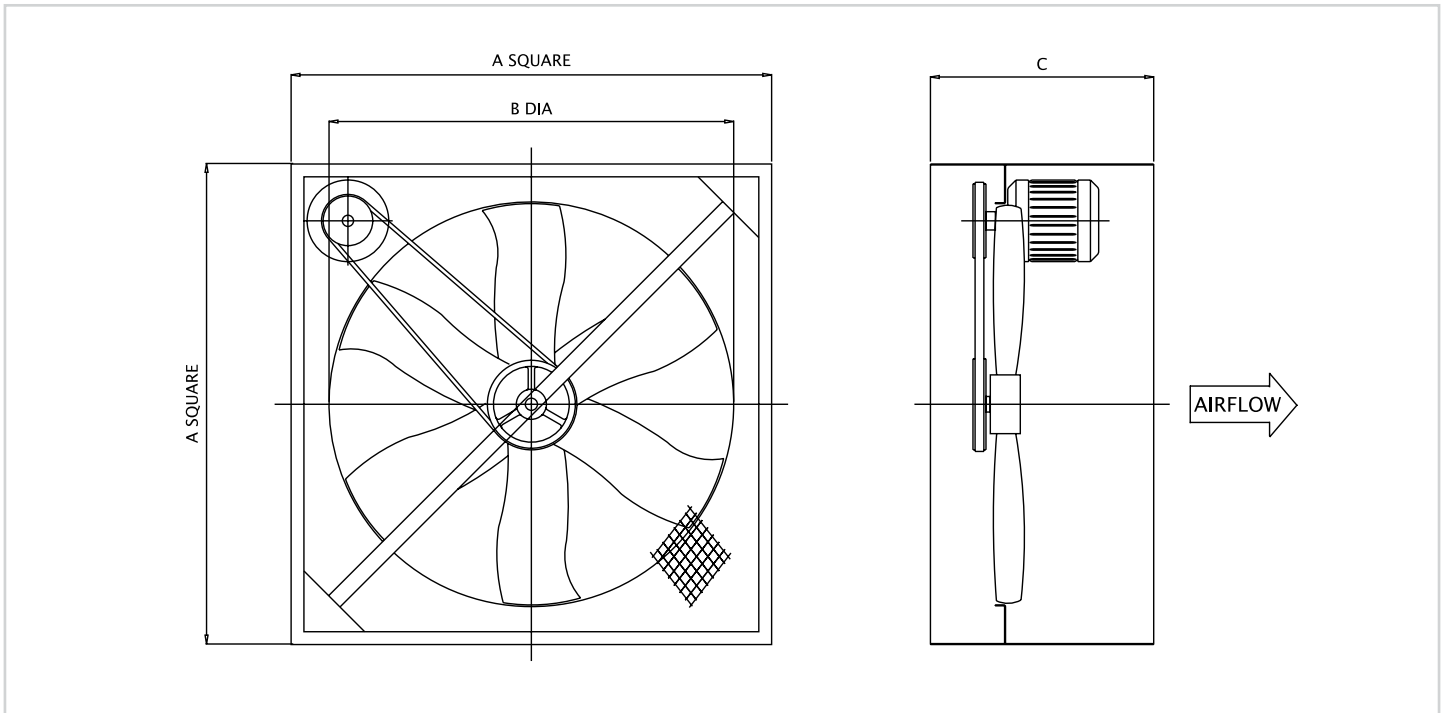

Product Code	Propeller Aperture (B)	Width (A)	Height (A)	Depth fan case only (C)	Depth inc Louvre	Depth inc Louvre & Guard	Weight (kg)	Weight inc Louvre (kg)
HV80	800	925	925	383	427	500	42	49
HV100	1000	1125	1125	383	447	515	58	64
HV125	1250	1375	1375	416	480	550	80	90